

TOP TECH

Abrasive Cutting

CF100/CF120/CF150

Spindle feed in
Z-axis ↑ ↓
for cutting

Special for
cutting long
sample

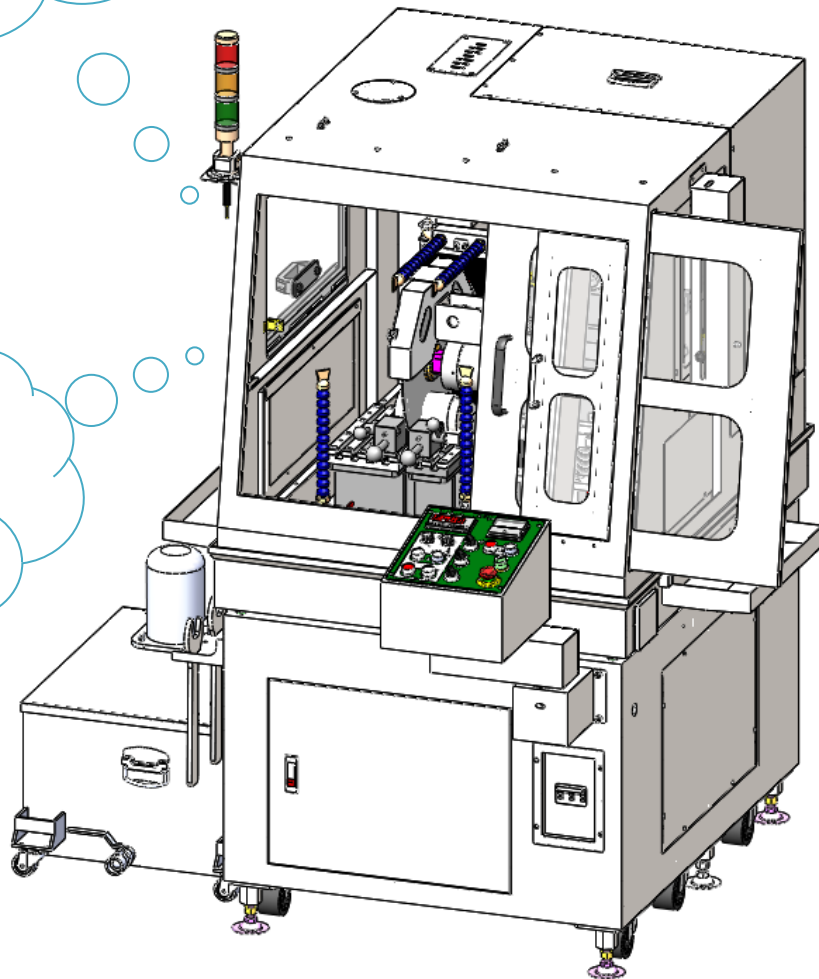



TOP TECH

Instruction

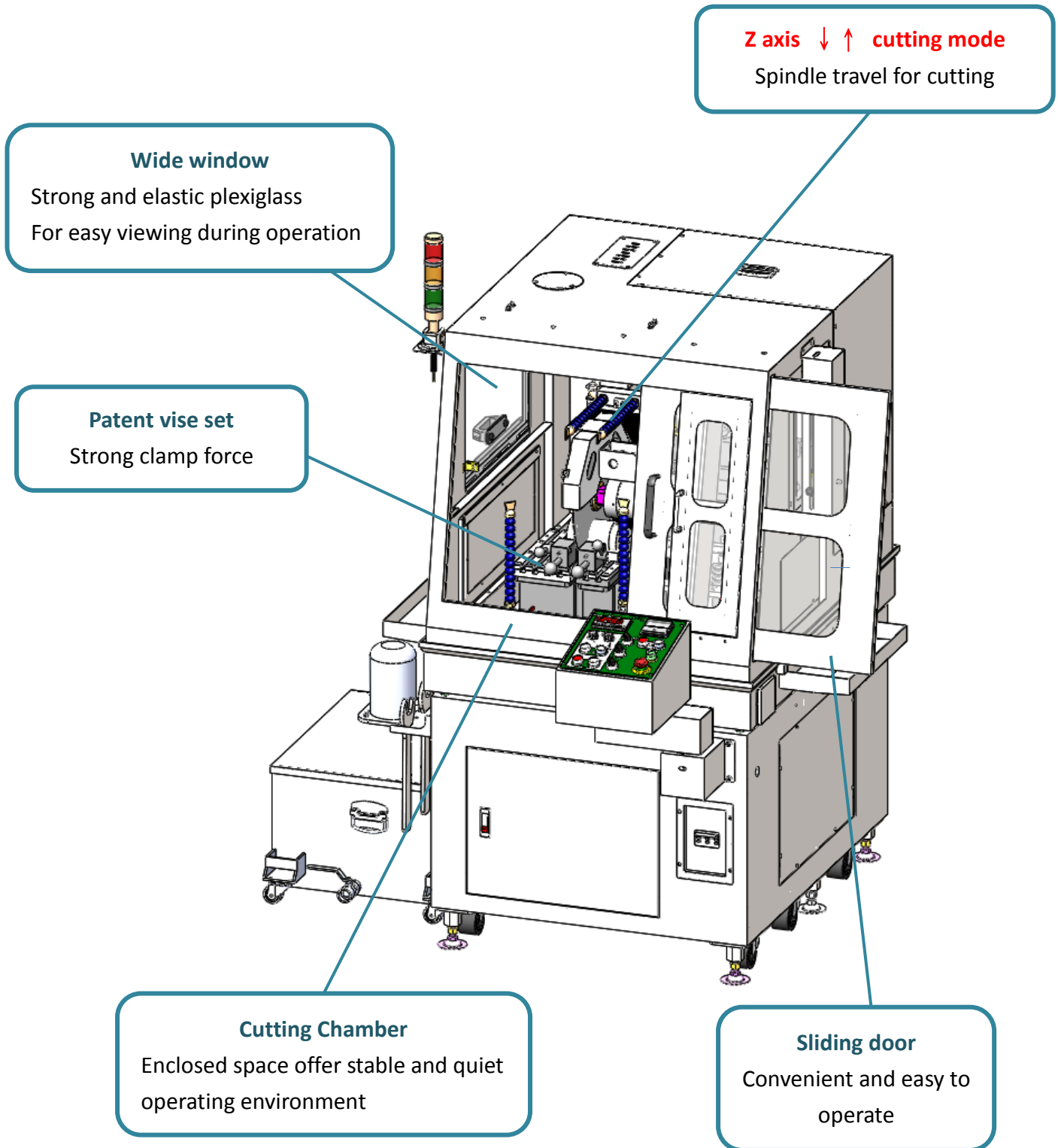





Features

Model	Description
CK001 Protection function of cutting load	Stop feeding automatically while overload. Start feeding automatically after machine is reset.

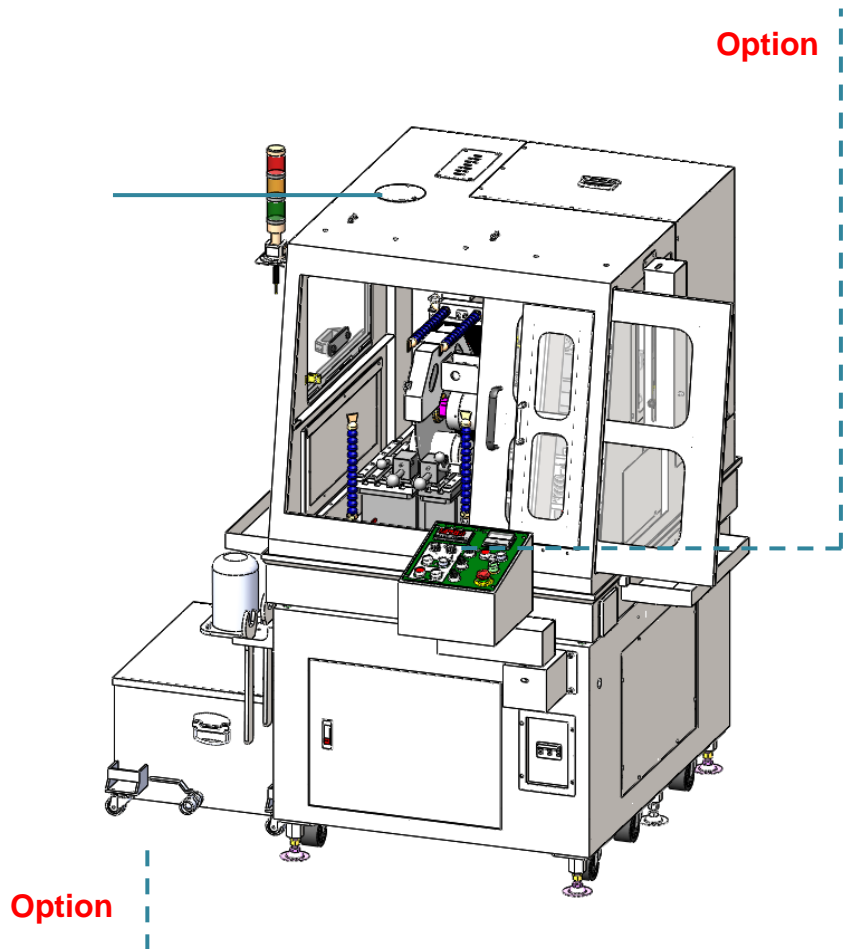

Vent allow to install ventilation equipment



Magnetic filtration coolant system	Paper filtration coolant system	Paper + Magnetic filtration coolant system
		

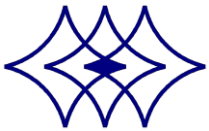

Model	Description
CF002 Option	<ol style="list-style-type: none">1. Feeding rack:3000mm (roller rack)2. Receive rack:1500mm(roller rack)3. Feed positioning :Precision 0.1mm , position length 1500mm4. Sample specification: ●Ø50 & ■100x205. Load: Max. 50Kg

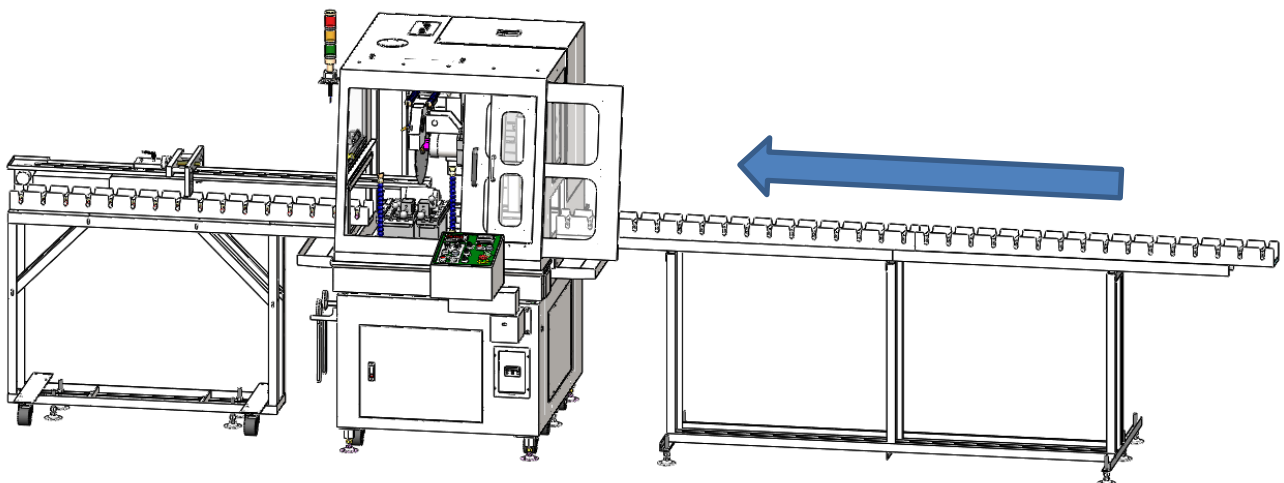



TOP TECH

Specification

Model no.	100	120	150
Travel distance	100	120	150
Motor power	2HP (1500W)	3HP (2300W)	5HP (3800W)
Cutting capacity(mm)	Max. Ø50	Max. Ø70	Max. Ø90
Cut off wheel	Ø255 x Ø31.75	Ø305 x Ø31.75	Ø355 x Ø31.75
Flange(mm)	Ø85	Ø85	Ø85 & Ø100
Feeding method (Automatic)	Automatic: button control/ Home point return after cutting		
Spindle rotational speed	3000RPM(60Hz) 2500RPM(50Hz)	2100RPM(60Hz) 1650RPM(50Hz)	2100RPM(60Hz) 1650RPM(50Hz)
T slot table(mm)	275x300	275x300	275x300
Vise dimension (WxD)	50x60 mm	50x60 mm	50x60 mm
Coolant pump	1/4 HP (190W)	1/4 HP (190W)	1/4 HP (190W)
Coolant tank	100L	100L	100L
Machine dimension (W x D x H)	1750(1800)x1510x2000	1750(1800)x1510x2000	1750(1800)x1510x2000
Power supply	AC 220V/380V /415V/440V Three phases		
Standard accessories	Spanner 2pc 、 Cut off wheel 2pc		
	Coolant 5L	Coolant 5L	Coolant 5L